

Yeovil Shopfront Design Guide

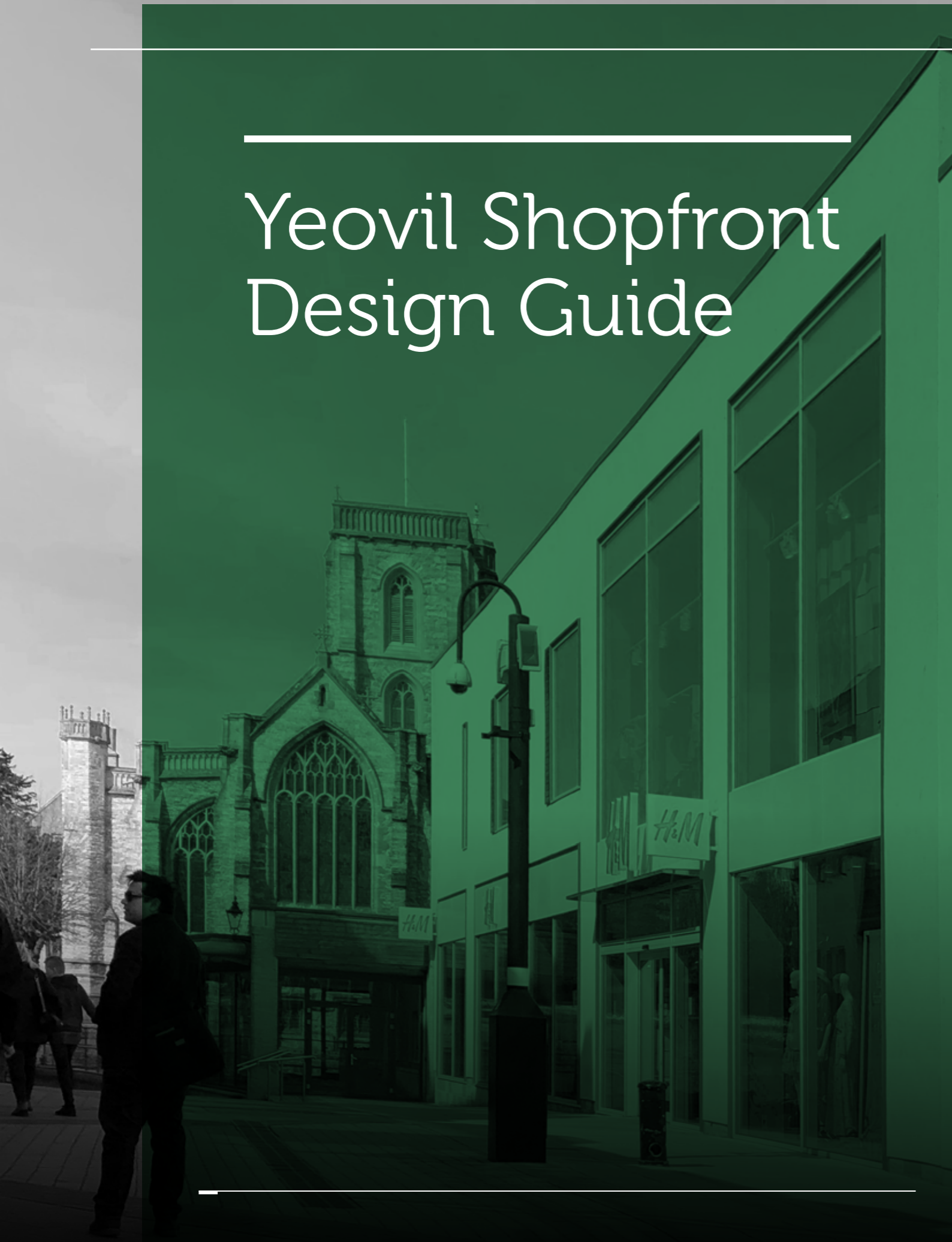

- 1. Introduction
- 2. Shopfront Design
- 3. Repairs & Maintenance of Existing / Traditional Shopfronts
- 4. Contemporary Shopfronts
- 5. Consents
- 6. Checklist
- 7. References & Further Advice

1. Introduction

- 1.1 The Purpose of the Document
- 1.2 Using this Guide

2. Shopfront Design

- 2.1 Shopfront Geneses and History
- 2.2 Shopfront Elements:
 - Cornice and Facia
 - Columns and Pilasters
 - Shop Windows and Forecourt Displays
 - Stallrisers
 - Doorways
 - Signage
 - Lighting
 - Blinds and Canopies
 - Security Measures
- 2.3 Materials and Colour Use
- 2.4 Accessibility

3. Repairs and Maintenance of Existing / Traditional Shopfronts

4. Contemporary Shopfronts

5. Consents

- 5.1 Planning Consent
- 5.2 Conservation: Listed Building Consent
- 5.3 Advertisement Consent
- 5.4 Building Regulations Consent

6. Checklist

7. Further Advice

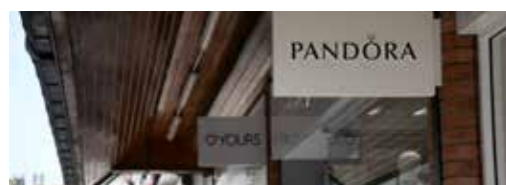

Report No	Author	Checked	Rev	Issued
19006 – Shopfront Design Guide	CC	-	-	Sep 2019

1. Introduction

Changes in retail methodology demanding larger shop units alongside the widespread use of relatively cheap materials and the standardisation of shopfront designs have resulted in gradual changes in shopping centres across the country and a loss of local distinctiveness. Generally, the character and quality of the traditional shopping street has often been eroded by poor, careless and unsympathetic alterations. Unsuitable shopfronts and gimmicky, disproportionately sized signs adversely affect historically or architecturally important buildings and demote the whole shopping area.

This Shopfront Design Guide has been produced by LHC Design and endorsed by South Somerset District Council to provide advice on the design of shopfronts that will positively contribute to Yeovil's character. It updates and expands on elements and advice given in the previously published document entitled "The Design of Shopfronts, Signs and Security Measures". This Design Guide forms supplementary planning guidance and will be a material consideration for planning purposes when looking to comply with the following policies (but not restricted to) contained in the adopted South Somerset Local Plan (2006-2028) adopted March 2015:

- **SD1:** Sustainable Development
- **SS6:** Infrastructure Delivery
- **EQ2:** General Development
- **EQ3:** Historic Environment
- **EP13:** Protection of Retail Frontages

1.1 – The Purpose of the Document

The appearance of shopfronts in a town centre or local shopping area has a profound impact on the area's character. Poorly designed and badly maintained street frontages detract from the visual qualities of an area and affect the retail viability and local economy. Suitably designed shopfronts are crucial for the preservation of the character of buildings and areas, as well as for the attractive overall appearance of shopping streets and the impact on their commercial success.

This document's purpose is to provide guidance for the designs of new shopfronts as well as for alterations, replacement and restoration of existing shopfronts, both in historic and contemporary settings. It does not aim to suggest precise ways of designing or to discourage imaginative and innovative new design, rather to encourage a sensitive approach to shopfront design. These guidance notes aim to set out basic principles of good shopfront design and to help to create enjoyable and attractive shopping areas in Yeovil.

Each proposal will be assessed in its own merit with good contemporary designs that are appropriate and have a good relationship with their context supported equally with strongly traditional designs.

1.2 – Using This Guide

Owners are encouraged to research and establish what would be the best design approach to suit their business and the building they occupy. Is the building listed, in a conservation area or are there any surviving historical features that ought to be preserved? Would a more creative design approach be appropriate or desirable? This guide can be used to check the building and visualise a range of design options. The right designer should be chosen, with proven experience in achieving the quality of work that is needed. Designers can use this guide as a checklist. Not all the headings may apply but they will assist in achieving the best design options for the client. Thorough research into the historic context of the building and character of the street, as well as ample consideration of how to complement the building and the streetscape with the new design will lead to a successful shopfront. Furthermore, confirming what permissions are required and investigating the existing building fabric, looking for evidence of previous designs which could be repaired and/ or incorporated will produce desirable results and enhance the street scene.

2. Shopfront Design

2.1 – Shopfront Geneses and History

During medieval times retail trade generally took place in the market and early shops were usually just variations of the market stall. Toward the end of the 17th century the idea of the shop window was introduced whereas the shop as we know it today emerged in the 18th century facilitated by the greater availability of glass.

Shopfront design has always been influenced by fashion and the prevailing architectural style of the time with designs traced back to classical origins. These classical proportions and design elements proved to be successful in achieving a pleasing symbiotic relationship between the building as a whole and the shopfront. Classical elements such as the columns and entablature, were used in a variety of ways, creating a frame for the window display and emphasising the entrance to the shop. Classical proportions and balance have been used in various ways through the centuries and though this is not the only way to design a successful shopfront, these principles continue to inspire contemporary designs.

Broadly speaking, from late 18th century to mid-19th century shopfront designs are predominantly Georgian, mid-19th to early 20th they are Victorian and 20th century designs tend to be Edwardian. However, despite changing details and materials, the same key components and basic principles of design and proportion are retained:

- Columns turned into pilasters that terminate in elaborately carved console brackets;
- Stallrisers fill in the bases between columns/ pilasters;
- The fascia replaces the entablature and a cornice finishes off the top;
- Height is visibly increased along with the width and depth of the shopfront;
- Unbroken window panes from cill to fascia, often only vertically divided by mullions;
- Doorways are recessed and mosaic forms the threshold;
- A greater variety of materials is utilised, such as tiles or marble, particularly for the stallriser and shop surround.

An effective visual frame to a shopfront window display serves more than just setting off the display of goods; it also serves an architectural role of visually supporting the upper part of the building and positively contributing both to the building's facade and the wider street scene.

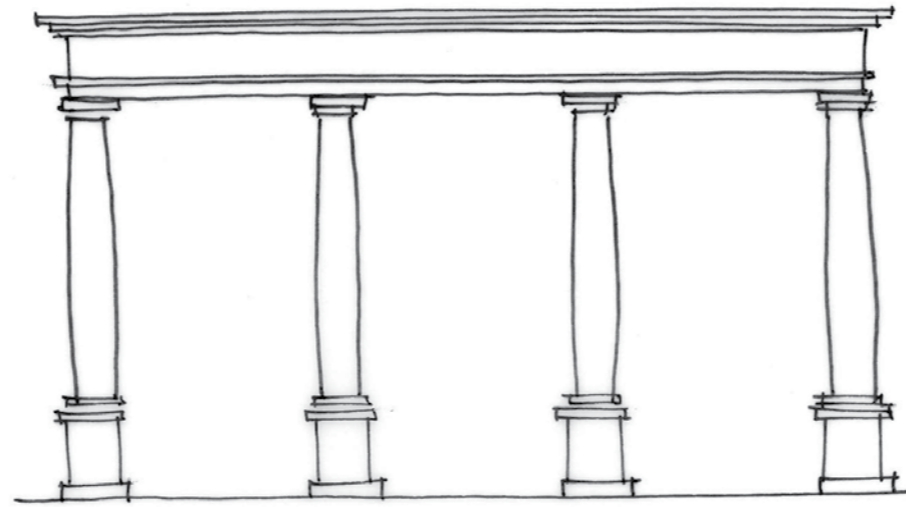

Figure 1. Classical Open Colonnade
Columns, plinths, entablature



Figure 2. Georgian Shopfront
Colonnade filled with glazing and stallriser

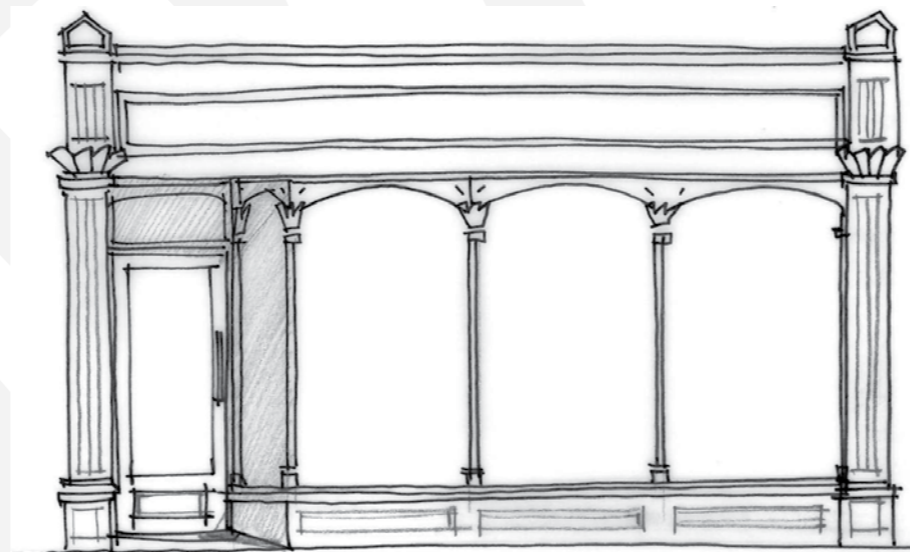

Figure 3. Victorian Shopfront
Highly decorative elements

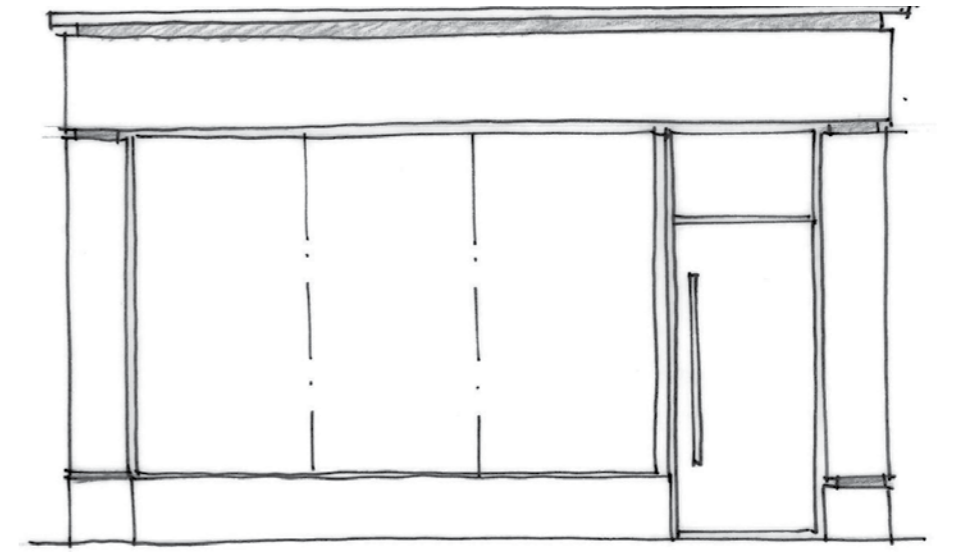

Figure 4. Contemporary Shopfront
Simplified design, retains classical proportions & main elements.

2. Shopfront Design

2.2 – Shopfront Elements

Shopfront designs can generally differ significantly in appearance, with varying styles, details and general design however, there are certain common features, which are identifiable in most variations such as the stallriser, fascia, and pilasters. Additionally, there are elements that echo consoles, cornices and fanlights, though these are often not in a traditional form. To produce a well-balanced shopfront these elements should be designed to be compatible in scale, proportion and materials with the overall building. Good design principles will also take into account the building's context in terms of scale, form and/or colours.

A new shopfront set in an historic building should generally incorporate these traditional elements, as such a design will likely form a successful relationship with the building that the shopfront occupies. It should also be noted that many historic buildings are broadly speaking, small in scale and overall have vertical proportions.

Cornice and Fascia

The fascia forms an important focal part of the shopfront as the space that advertises the business. Its style and proportion should therefore be designed to relate well to the surrounding building and shops. Furthermore, its design should be appropriate to the character and period of the building as it shapes the link between the ground and upper floors.

Georgian and Victorian shopfronts traditionally have upright fascias, set in a frame enclosed by capitals or console brackets, with either plain or decorated ends, supported by pilasters. Later fascia styles are often inclined outward so that they can be read more easily.

Fascias are customarily topped by a stepped, projecting cornice. The shadowing under the cornice provides a visual stop to the top of the shopfront and separates the shop from the upper floors of the building. Additionally the cornice serves a practical purpose in providing weather protection for the fascia signage below.

Good design principles

- Fascia dimensions should be directly proportional to the size of the shop and building that it occupies; as a rule of thumb should be between a fifth and a quarter of the shopfront height. Additionally, there should be a sufficient visual gap between the top of the fascia/ cornice and the upper floor window cills;
- Fascia height should not be increased in order to conceal internal suspended ceilings. Careful detailing of the shop window itself can be utilised to deal with such an issue, such as introducing an opaque transom light or setting the ceiling sufficiently back from the shopfront;



Figure 5. Traditional Shopfront Elements

Figure 6. Cornice & Fascia Proportions

KEY	
1	Cornice
2	Fascia
3	Blind Box
4	Console Bracket
5	Capital
6	Pilaster
7	Plinth
8	Window Display
9	Mullion
10	Transom
11	Transom Light
12	Fan Light
13	Shop Entrance
14	Cill
15	Stallriser
16	Entrance to Upper Floor

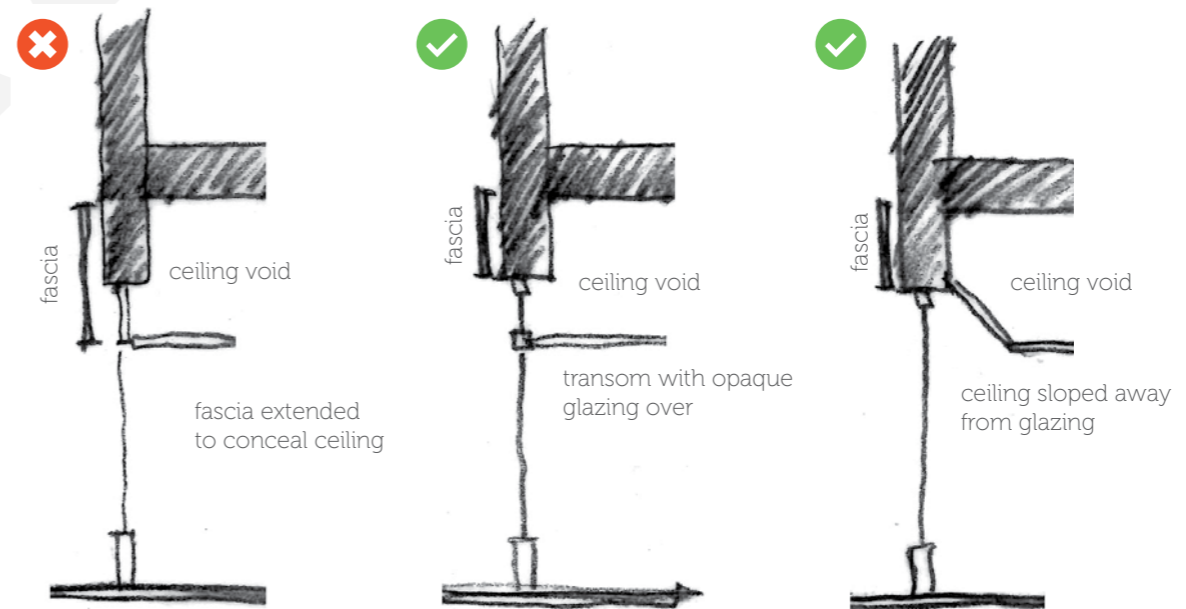

Figure 7. Ceiling Relationship to Fascia

Good design principles (continued)

- If a shop occupies two or three adjoining buildings, the architectural character, rhythm, height and scale of the buildings above should be reflected below; a single, large, overbearing fascia sign will not be supported;
- Fascias should be designed to be contained within the pilasters/vertical shop front surround and should not obstruct any other architectural detail, such as cornices and corbels;
- Modern, internally illuminated, boxed fascias, which project from the face of the building, detract from the building character and adversely affect the street scene;
- Signage should be applied directly to the fascia, avoiding new fascia boards additions over existing;
- Large flat fascias, or reflective/ polished materials are generally undesirable in existing historical buildings; the signage becomes difficult to read and the materiality is uncomplimentary to the building and context;
- Corporate organisations should adapt their advertising and signs to suit their sensitive surroundings.



Figure 8. Fascias designed disregarding individual buildings, features and street rhythm



Figure 9. Fascias designed sensitively to context and buildings' setting

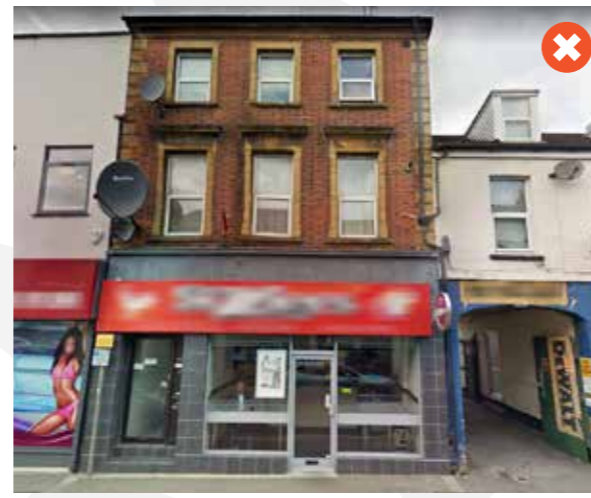

Figure 10. Fascia applied disregarding the original zone



Figure 11. Fascia applied disregarding the building and obscuring pilasters

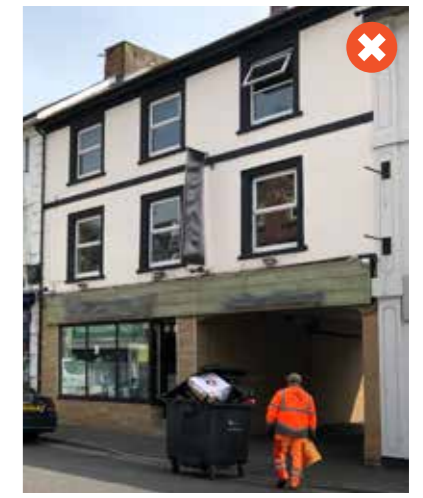

Figure 12. Fascia applied obscuring archway



Figure 13. Corporate design successfully applied respecting the building



Figure 14. Corporate design successfully applied respecting the building

Consoles and Pilasters

Pilasters are shallow piers or rectangular columns projecting only slightly from the building's facade wall. They function as a frame to the shopfront and accentuate the subdivision of the frontage into separate units. They also provide a visual support to the fascia above.

Traditionally pilasters are made of wood, and tend to be thin and decorated. Much like their predecessors the columns, pilasters have a base, often reflecting the height of the stallriser. The top of the pilasters are finished with a projecting head: the console bracket. This will usually have the same height as the fascia and in many cases allows the latter to be installed at an angle. Console decorations tend to be elaborate in traditional designs.

It is highly recommended to retain original pilasters and repair them as required. Covering them will damage the character of the original design; reinstatement, uncovering, repairing and renewing is encouraged when any new shopfront design is proposed.

Good design principles

- Traditional shopfronts should incorporate pilasters and these should include a base and a capital;
- Contemporary shopfront designs may not necessarily require the inclusion of a pilaster. Nevertheless, in principle a clear division between shopfront units should be incorporated and the upper part of the building should be visually supported. This can be accomplished, for example, by incorporating or retaining flanking masonry piers and, where necessary, including piers within the shopfront itself.

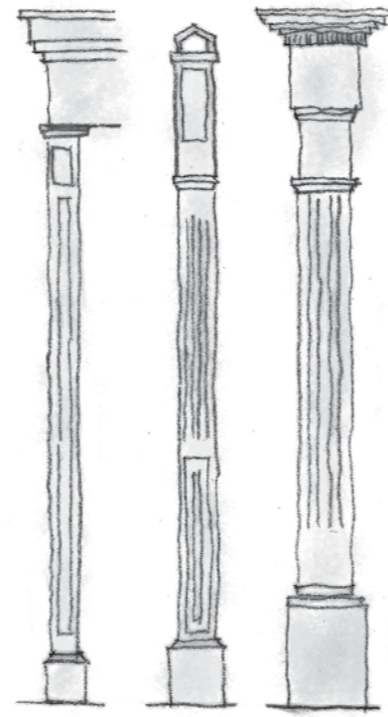

Figure 15. Traditional wooden pilaster designs



Figure 16. Successful pilasters design, the left incorporates a console bracket

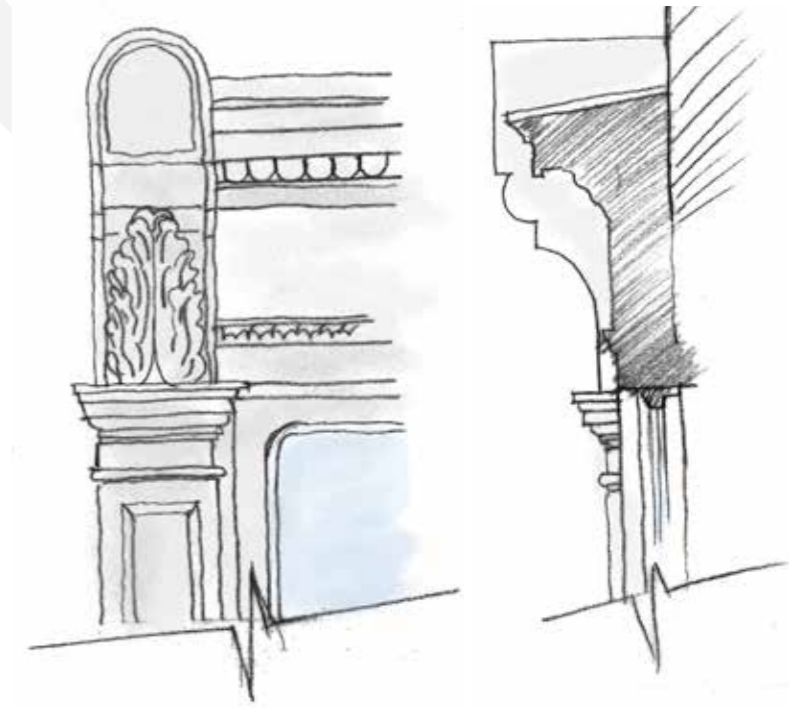

Figure 17. Ornate console bracket example



Figure 18. Projecting cornice, fascia and the capital topping the pilaster details respecting the building character – no console bracket.



Figure 19. Console brackets allow fascias to be installed at an angle

Shop Windows and Forecourt Displays

Shopfront windows' primary functions is to display the goods sold in the shop. However, they also allow inside activities to be seen from the outside thus enlivening the street scene and promoting natural surveillance. Varying glazing finishes, such as engraving, can add interest to the shopfront's appearance and can be utilised as a high quality advertising opportunity or a chance to show off the nature of the business.

Historically shop windows are subdivided by mullions and transoms, often in timber. These subdivisions reflect the proportions of the shop and the rest of the building's elevation and are in keeping with the character of the street. Additionally, this subdivision assists in the creation of human scale proportions to the frontage, gives stronger visual appearance and aids security.

In contrast, contemporary shopfront windows tend to have large expanses of glass as principal feature of the shopfront design and that can work well in contemporary buildings within modern shopping areas.

Shop forecourts containing an attractive display can significantly add to the appearance of a shopfront and the visual interest and vitality of the street. Private forecourts can be enclosed in materials complementary to the building and its context, subject to planning permission and listed building consent as and where required.



Figure 20. Timber mullions and transoms subdividing shopfront display

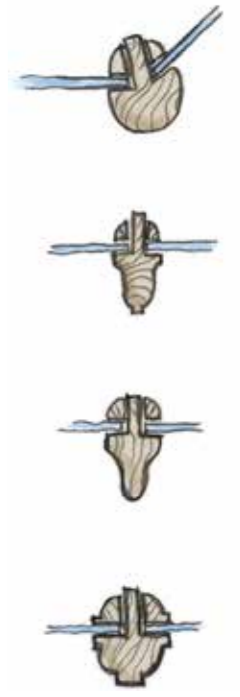

Figure 21. Timber mullions detail and various moulding profiles

Good design principles

- Shopfront windows in historic buildings should be subdivided vertically, making them taller than wider, thus reflecting the smaller scale of the building and its overall vertical proportions;
- Large glazed areas should be avoided in historic areas as they have a disruptive and dominating effect;
- Where a business occupies more than one adjoining premises, the display windows should not expand over more than one building to avoid disrupting the street scene rhythm;
- Transom divisions should be positioned to divide the window at door height. Mullions should be positioned such that they line up above and below any transom divisions and can reflect the alignment of windows in the upper levels of the building;
- Timber profiles in traditional window subdivisions should not be rectangular in section, but moulded. Broadly speaking tapered, lambs-tongue or rounded sections are preferred as these give a more slender appearance and subtle shadow lines;
- Where a forecourt display of goods is proposed, public footpaths must not be obstructed or encroached upon and any paving materials proposed should be complementary to the adjoining paving. Wheelchairs, prams etc as well as the partially sighted must be considered when siting outdoor items such as tables, advertising boards and such like items that can pose an obstruction.



Figure 22. Contemporary shopfront in historic building designed to incorporate historic details



Figure 23. Contemporary shopfront in modern building

Stallrisers

The stallriser is defined as the solid panel below the shop window. It functions to reduce the predominance of glazing and raise the level of the window display. It provides the building with a visual anchor to the ground and affords some protection to the shopfront against accidental knocks, and if suitably reinforced, against ram-raiding.

Conversely, modern shopfronts have large expanses of plate glass, down to ground level. This approach increases the view into the shop and breaks down the barrier between inside and outside. It results in a dramatic and effective display area however, such minimalist design is generally not appropriate in parades of shops where the display areas are more conventionally framed. It works better in internal shopping malls and for well-designed modern shopfronts, in contemporary settings

Stallriser heights vary according to the overall proportions of the building, as well as the nature of the business and how much window display area is needed.

Good design principles

- Stallrisers should be incorporated into designs for new shopfronts in existing historical buildings;
- Stallriser height should not generally not exceed the base of the pilasters or approximately 450mm. However, there may be situations where the height could or should be increased, planning advice should be sought accordingly;
- Stallrisers should be made of substantial materials and be compatible with the shopfront frame and upper building. Suitable materials to be used are: painted timber panelling, ashlar stone, render, and brick in some situations. The following materials will not be supported and should be avoided: rubble stone, polished stone, marbles, granites and other non-local stones, mosaics, ceramic tiles, acrylic sheets, and composite or tongue and grooved boards;
- Where a stallriser is being replaced, the chosen material must relate to the building and its context;
- Proposed timber panelled stallrisers should have properly detailed panels and not applied surface mouldings to create a panelled appearance as a substitute for proper joinery.
- The stallriser should terminate in a moulded projecting cill and a sub-cill to create a clear horizontal distinction between the window and the base

Doorways

The doorway is an important visual element within the shopfront. Traditionally doorway entrances were recessed, sometimes with splayed sides, providing an inviting lobby area and offering protection from the weather. This also assists in increasing the available window display area and breaks up the scale of the shopfront, adding detail and interest to the street scene. The floor is usually decorated with tiles and mosaics, which sometimes incorporates the name of the original shop owner. The soffit in the lobby area was often panelled, and the glazed panelled doors had ornate ironmongery.

The entrance can be positioned centrally to the shopfront off to one side. Doors leading into the shops should reflect the design of the shopfront, having a kick plate or solid panel matching the height of the stallriser as well as a fanlight over matching the height of the transom division (if any) of the window display. Two thirds glazed doors are best for the shop entrance and solid timber doors are best for upper floors' access.

Good design principles

- Entrance doors should be designed appropriately to match and be sympathetic to the period and style of the shopfront;
- Removing or changing a recessed doorway into an opening straight onto the pavement will not normally be supported;
- Doorways should be designed to be accessible to all, including those with physical impairments, and people pushing prams etc. New doorways in particular should be wide enough to allow for the passage of wheelchairs and preferably be a single leaf door in line with relevant regulations and standards.
- Thresholds should ideally be level, but if raised, a door recess can accommodate a ramp. This should be designed in line with relevant regulations and standards. Please also refer to the Accessibility section later in the document.



Figure 24. Recessed doorway and increased window display, door matches shopfront style



Figure 25. Recessed doorway, shopfront style matches building setting, panelled stallriser

Signage and Advertising

The fascia element of a shopfront is the primary location to advertise the name of the shop and nature of the business. A well designed sign will generally enhance the appearance of the shopfront and add interest to the street scene. It should be noted however, that planning, listed building and advertisement consent may be necessary for advertising and shop signage.

As mentioned earlier in the document, the fascia plays an important focal role in the overall shopfront design and as such the design of the shop signage located within this zone should be sensitively done and relate to the overall shopfront design.

Lettering within the fascia is a key component of signage design and should be considered and implemented sympathetically. Originally such lettering was hand painted onto the painted fascia and in traditional settings this approach yields successful results. Alternatively, individual letters made of wood, cast aluminium, bronze or brass are also an attractive solution. Letters should be sized appropriately for the size of the fascia and the setting of the shop and the degree of projection should be carefully considered.

For larger stores, and in wide streets, a larger scale of signage may be appropriate. However, oversized fascia signs that obstruct other building elements will not be permitted in any case.

Where a shopfront does not have a fascia zone, individual letters may be applied on the wall between the ground and first floor levels. However, signage above the first floor cill level will be strongly resisted. An alternative approach is to incorporate lettering and decorative signs into the window display.

New fascia boards should not project beyond the original facade. Modern, factory produced fascias of plastic, acrylic or similar materials, often internally illuminated, are unsympathetic and out of place on buildings of traditional design. They detract from the street scene and generally contribute to a low quality environment. This type of fascia is generally only acceptable on modern buildings, however, they must be appropriately integrated into the overall shopfront design, and be suitably sized.

Utilising A-boards and other similar type of on-street advertising creates visual clutter, obstructs pedestrian movement and therefore should be avoided. It would however be acceptable within the private forecourt of the shop, where it does not hinder pedestrian movement. Modest designs, sizes and colours should be used, in keeping with the fascia design.

The installation of Estate Agent 'for sale/ let' boards on or above shopfronts should be avoided over and above what is permitted as deemed consent in national regulations.

Other signage or advertising displayed at a high level will rarely be acceptable, particularly if it is large, on flank walls, or visible from residential areas.

Projecting signs are a traditional form of additional advertising of commercial premises. When carefully designed to complement the fascia colours and design, they can add interest and originality to a building and street scene. Other contemporary solutions to shopfront signage will not be discouraged and each case will be considered in its own merit.

Good design principles

- Signage in the fascia zone should be restricted to that necessary to identify the name and service of the shop and should be sensitively integrated into the overall shopfront design;
- Projecting boxed fascia signage should be avoided, particularly in conservation areas;
- Lettering font and application should be chosen to suit not only the business it advertises but also the building and its context. It should be applied directly to the fascia, avoiding adding new fascia boards over existing;
- Fascia signage consisting of lettering should be in proportion to the fascia dimensions itself, with sufficient margins around the actual letters and appropriate colour contrast to ensure legibility and decrease visual clutter and confusion ;
- Corporate signage of chain outlets should be adapted to suit sensitive surroundings as appropriate;
- Projecting signs should be modestly sized, slim-profile, non-illuminated, of a style that complements the fascia and constructed of materials which complement the shopfront. They should be fixed at fascia level, on the side that is commonly used by other shops on the street and ideally positioned centrally on a pilaster but not fixed to the console bracket. To prevent visual clutter only one small, projecting sign will be allowed per frontage.
- The maximum projection width of a projecting sign should be between 750-900mm and the height should be between 300-375mm. The bulky type, commonly used in modern shopfronts, and formed by a box steel casing with illuminated acrylic panels, downgrades the appearance of a shopfront and is not recommended.
- Projecting signs should not be used on listed buildings and in conservation areas, unless it has been identified as an original characteristic of the building or the area.

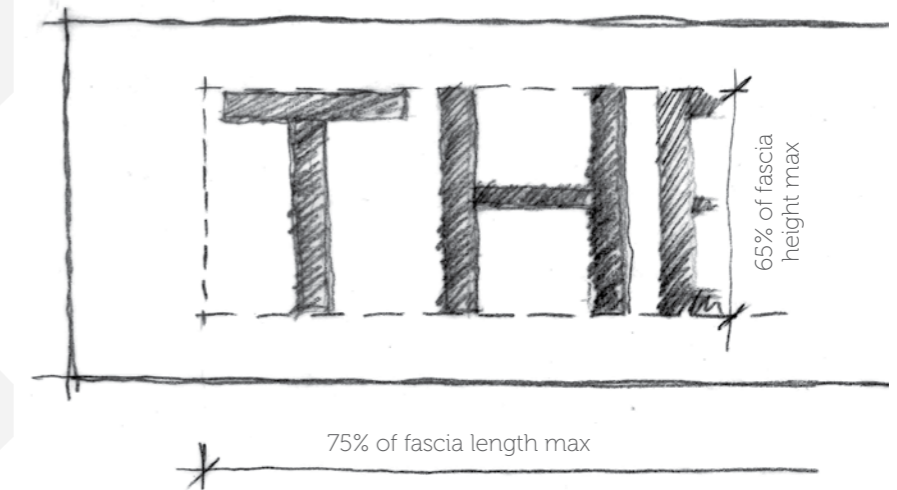

Figure 26. Signage lettering dimensions proportional to fascia dimensions

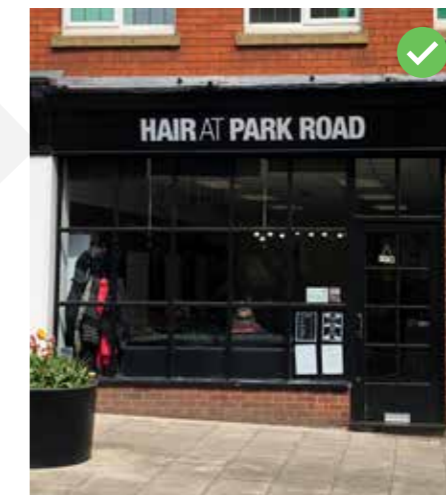

Figure 27. Legible and well proportioned lettering



Figure 28. Signage disregards building elements

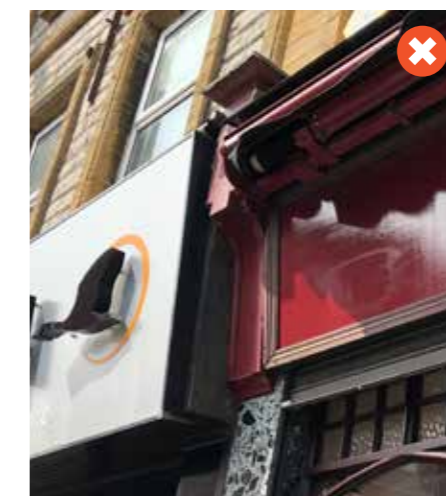

Figure 29. Boxed and projecting fascia on the left detracts from the building



Figure 30. Excessive number of signs ill-positioned detracting from building



Figure 31. Successful signage strategy in historic setting



Figure 32. Successful signage strategy and overall shopfront arrangement, though the colour scheme could be improved

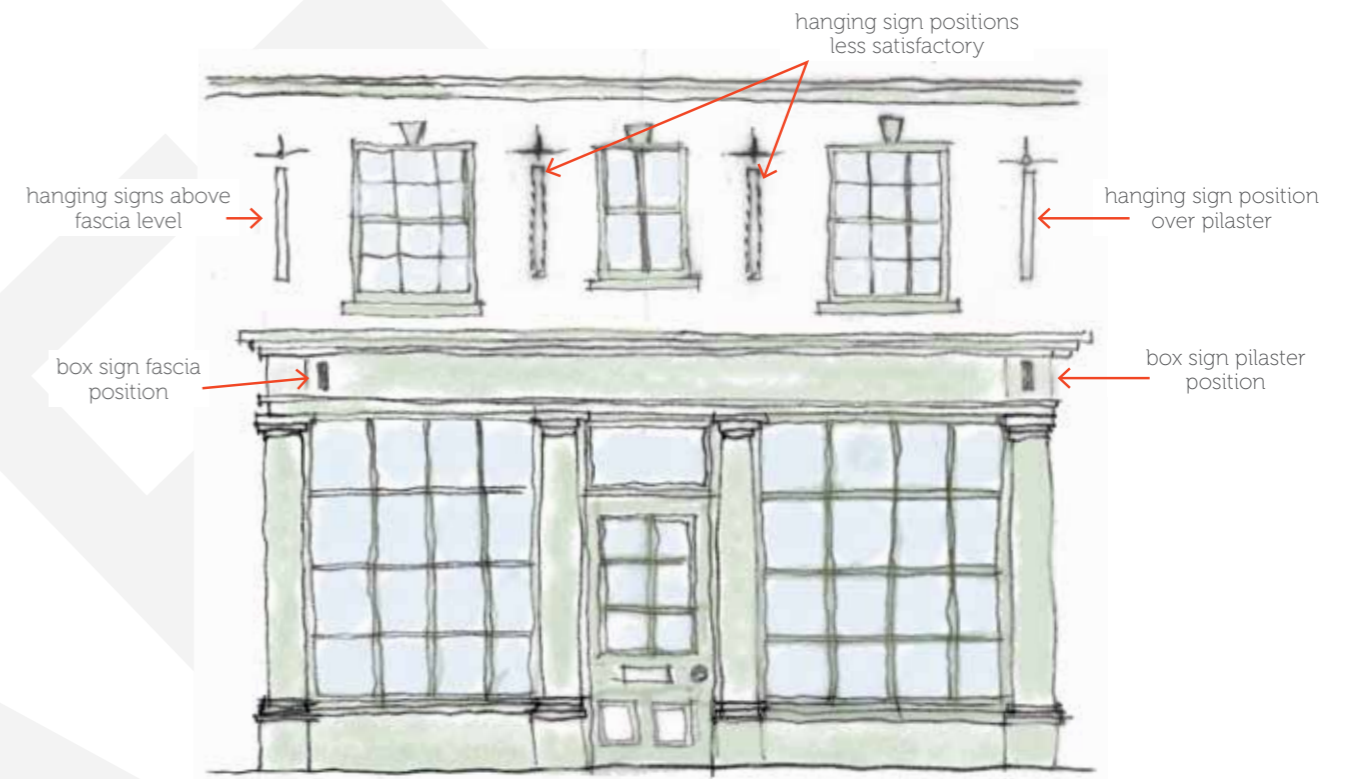

Figure 33. Hanging sign is well positioned but projecting box fascia sign detracts from building character



Figure 34. Hanging sign well positioned and proportional to building



Figure 35. Bulky internally lit hanging sign detracts from building



Figure 36. Modern box sign positioned on pilaster



Figure 37. Successful lettering on building



Figure 38. Successful lettering on building

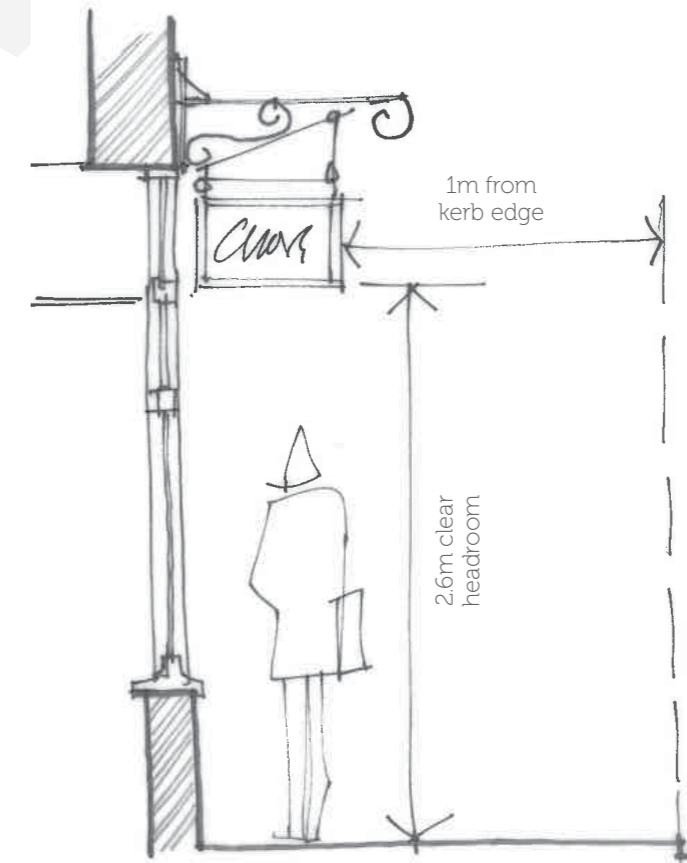

Lighting

Internally illuminating the shopfront display will contribute positively to an area, encouraging window shopping during out of business hours and adding security by deterring vandalism and antisocial behaviour. Conversely, internally illuminated signs often look bulky and detract from the character of the shopping street. Similarly large, projecting light fittings can be just as intrusive, however, it is accepted that illumination of signs and fascias may be appropriate in some situations.

In conservation areas and for listed buildings illuminated signs will normally only be necessary for late opening premises, such as public houses and restaurants. In instances where additional lighting is required, much like the other elements of the shopfront, it must be designed to respect the building and be appropriate to the area.

Good design principles

- Where external lighting is required it should be restricted to an absolute minimum and discreetly positioned;
- Where fascias are proposed to be illuminated with external fittings, these must be carefully and unobtrusively be designed to avoid the lights themselves becoming permanent features on the face of the building. A good solution is to conceal the fittings within or beneath the cornice of the fascia;
- Lighting brackets should be either of a traditional or an unobtrusive, simple modern design and should be painted to match the background colour of the building (if this is rendered) or in black, or bronze anodised;
- Internally illuminated box signs, fascias and individual signs will not generally be acceptable, particularly in conservation areas and on listed buildings. If proposed, they should be strictly limited to a fascia located as an integral part of the actual shopfront. Additionally, careful detailing of the edges will be necessary to ensure an image of quality is portrayed;
- Acceptable forms of lighting could include individual letters halo illuminated or discreet hooded spotlights. Conversely, internally lit letters can be bulky, brash and difficult to read from the side; these will generally be resisted. In addition, neon and fluorescent lighting is out of place in historic areas and other areas of significant amenity value.



Figure 39. Successful discreet lighting



Figures 40 and 41. Successful discreet lighting



Figure 42. Lighting brackets misaligned and detract from building and sign



Figure 43. Lighting brackets too bulky and unattractive

Blinds and Canopies

Canopies and blinds function to provide protection to pedestrians and the shop window against the weather. They can be a lively addition to the streetscene, provided that they are designed as an integral part of the shopfront and are confined to it. They should not be introduced as a form of advertising space but always be functional and retractable.

Modern "Dutch" blinds are not appropriate as their form and the shape of the housing is does not relate well to existing shopfronts or historical buildings, thus this type of blind should be avoided.

Good design principles

- New blinds should be properly integrated within the design and construction of the shopfront. They should be positioned below the fascia so as not to obstruct the shop sign and, when retracted, should sit flush with the fascia;
- Proposed blinds should always be retractable when not required and ideally be of a traditional roller design. Fixed blinds or "Dutch" blinds are generally not acceptable;
- The proposed size, shape, and position for a blind should be compatible with the character of the building. Architectural details of both the shopfront and the building should not be obscured when blinds are installed;
- Materials for blinds should be nonreflective. Wet look material, shiny plastics, garish or fluorescent colours are unsuitable as additions to almost any shopfront;
- Where traditional canvas blinds and blind boxes are still in place, these should be retained and restored.



Figure 44. Well integrated retractable blind



Figure 46. Well integrated retractable blind



Figure 47. Blind box not well integrated with shopfront



Figures 45. Dutch type blind too bulky and obstructive

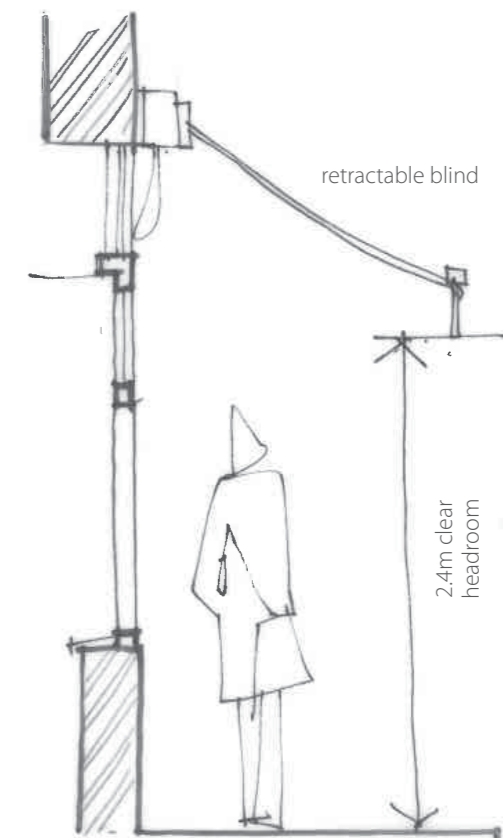

Security measures

A major aspect of shopfront design which can affect the whole character of a shopping area is the method of implementation of security measures; external shutters, box housings, guide tracks, locking devices etc. can all add to the creation of a potentially lifeless and hostile atmosphere. The need to provide adequate security versus the maintenance of the quality of the environment of shopping areas must be carefully balanced. Shop owners are encouraged to discuss proposals and requirements both with their insurance company and the planning team before any work is carried out.

The three major elements of crime that ought to be considered where assessing security requirements are theft, vandalism and ram raiding. Risk levels will depend on a variety of factors, such as the nature of the business and its location, the way the street is laid out and lit, and the level of activity in the area outside normal shopping hours. The local Architectural Liaison Officer will be the main source of advice for particular problems in any given area.

Good design principles

In order to integrate security measures without adversely affecting the character and appearance of a building and the area where its situated, the following general principles apply:

- Security measures should be an integral part of the design for any new shopfronts. The shop frame should be used for designing protective measures and the shop window could be divided into several panes by mullions and transoms making it less susceptible to wilful damage and cheaper and more easy to replace as necessary;
- Planning consent will be required for installing, altering or replacing shutters or grilles on the exterior of a building.
- Any proposed alteration that affects a listed building's special architectural or historic character either externally or internally will require listed building consent as well as planning permission;
- Planning consent will not normally required for internal security grilles however, listed building consent will be necessary for listed buildings;
- External fittings such as alarm boxes will normally require planning permission as well listed building consent where appropriate;
- Each proposal will be assessed on its own merit, taking into account the need for security, the likely effect upon the shopfront and building itself, the adjacent buildings and the locality or streetscene.
- Planning consent may be granted with appropriate conditions to avoid the retention of certain security measures necessary for one type of business but not for another.
- The likely risk to any business and its shopfront should be assessed and the appropriate security measures then proposed. Advise should be sought from the insurance company and police whilst the security of the building as a whole should be considered; often the rear of a property is more vulnerable to break-ins whereas the front is more at risk of casual vandalism;
- A visible and illuminated shop window display will positively contribute to the street's character, permit after-hours window shopping and enhance natural surveillance. Additionally an internally illuminated display both in the windows and within the shop will increase light levels in the street after dark, enhancing security of both the interior of the premises as well as the area. Consequently security measures which do not obscure the window display will be preferred.

The following possible security measures are written in order of preference from a standpoint of limiting possible detrimental impact on a shopfront and the streetscene.

- Suitable security can be achieved through suitable specification of the shopfront glazing such as toughened and laminated glass.
- Alarm systems utilised in conjunction with internally illuminated glazed shopfronts constructed with security glazing will provide sufficient security to most shops. However as they can be rather unattractive devices, they should be sited as unobtrusively as possible and must not obscure or damage any architectural details. The most suitable location will be immediately above the fascia at one end, or, if the box is placed on the shop front itself, at one corner within the depth of the fascia. They should be painted to match the background colour.
- Where shutters for security are necessary, utilising internal grilles will be generally preferred over external shutters. Internal grilles are retractable during shopping hours and can be discreetly installed behind the shop window. An open link grille type will permit a clear view into the shop, thus allowing natural surveillance and lighting to spill into the street thus continuing an open appearance. The installation of internal grilles does not require planning permission, although it will require Listed Building Consent if the shop is part of a Listed Building.
- External, removable mesh grilles or wooden shutters are another traditional means of providing security. Fixed over the shop window and the entrance, they do not require any box housing and can be stored inside the building or folded back when not in use.
- External roller grilles may be considered if the above security measures do not suffice. Solid metal shutters will not be acceptable except in exceptional circumstances, where evidence, supported by the police, has proven that there is a particular security problem in the area and all other appropriate security measures have failed to address this. Where external grilles or shutters are permitted, the shutter box must be installed recessed into the shop. Traditionally this has been behind the fascia panel. Where this cannot be accommodated, an opaque transom light could be introduced to conceal the shutter box. Careful consideration should be given to the positioning of the shutter guides in the shop frame. They should be integrated into the shopfront design or be removable, and colour coated to match the shopfront.

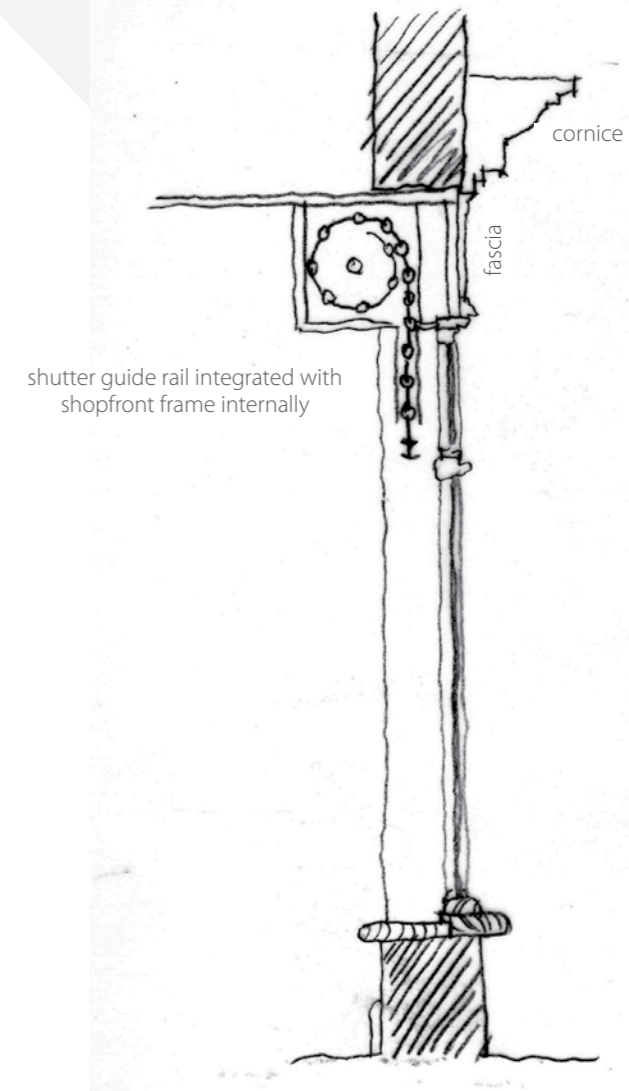

shutter guide rail integrated with shopfront frame internally

Figure 48. Internal roller shutter position, well integrated with shopfront



Figure 49. Closed type, external shutter unacceptable in any case



Figure 50. Open type, external shutter acceptable only in necessary situations



Figure 51. Alarm boxes haphazardly positioned on facade



Figure 52. Open type, internal shutter integrated with shop type, generally acceptable



Figure 53. Well integrated, open type external shutter acceptable in necessary situations



Figure 54. Alarm boxes haphazardly positioned on facade

2.3 – Materials and Colour Use

Selecting materials for shopfronts must always take account of the style and design of the proposed design, the building it will occupy and its setting.

A limited palette of good quality materials will always work better in integrating the proposed shopfront with its surroundings and positively contributing to the character of the street. Broadly speaking nonreflective finishes should be utilised and the use of plastics, mosaics, polished stone, ceramic tiles, smoked or mirror glass should be avoided.

Timber

Timber is traditionally used for shopfronts. It is versatile and the most appropriate material in all situations, whether in a historic setting, a conservation area, a listed building or for a contemporary design. The choice of timber should be carefully considered at the design stage as it will have a considerable bearing on the visual appearance and future maintenance requirements of the shopfront. The use of tropical hardwoods and all timber from non-sustainable resources should be avoided. The Timber Research & Development Association (TRADA) can provide advice and technical information regarding the availability, quality and performance of timbers.

Generally, timber should be finished with paint; varnish or stain may occasionally be suitable but not in conservation areas or for listed buildings. There are nearly infinite choices available in colour and design for timber and it can normally be easily repaired or altered and readily repainted for a fresh look.

Stone

Stone is broadly appropriate in all parts of South Somerset but typically only in the form of smooth ashlar. If stone is to be chosen for a shopfront, the type should be carefully selected and it should preferably be local to the area. Random or rough rubble finishes are not suited to shopfronts. It should be noted that for listed buildings and in conservation areas full details of the stone coursing, bedding, jointing, pointing and mortar mix will be required.

Brick

Brick may look out of place unless the building itself is constructed of brick. Each opening in a stone or brick building will require the wall's means of support to be physically expressed, weather as a beam or lintel or some form of arch.

Render

Render is only really suitable for stallrisers or, if executed to the highest possible standard to emulate ashlar stone.

Metals

Aluminium is often used for modern shopfronts; powder coated finishes have a good appearance and are available in a wide range of colours. Generally the use of self-coloured and anodised aluminium should be avoided.

Unfinished galvanised steel should be avoided. As with aluminium, powder coating can provide a good finish in a wide colour range.

Chrome plate, stainless steel and other polished metals are usually too hard and shiny in appearance but can be suited to very specific design solutions.

Plastic & Acrylic

Plastics are not generally appropriate in conservation areas or for listed buildings. They are however often used for modern signs, facias and lettering. Selecting and designing with plastics should be done carefully to avoid a thin, harsh, shiny appearance and detailing the finish at the edges of sheets should be well-considered.

Colour Use

A place's character and local distinctiveness is partly determined by colour as well as the predominant materials used. As such the choice of shopfront colour will play an important role in positively contributing to the locality perhaps by the use of a locally distinctive colour or variation upon it. Therefore, the choosing a colour should be done with regard to the colour qualities of the building as a whole as well as those of the neighbouring buildings and their setting, in order to avoid clashing contrasts.

Selecting colour requires skill and judgement. Generally colour schemes for historic shopfronts were kept simple, often single-coloured that puts the visual focus on the goods displayed in the shop window. Conversely, contemporary colour schemes are often used to make the shopfront itself a form of advertising. Corporate schemes in particular are often imposed without any regard to the design and location, which often contributes to the erosion of the character of an area. Thus, in historic areas corporate colour styles may need to be modified from their standard design. Listed building consent may be needed when repainting a listed building; advice should be sought from the Local Planning Authority.

Good design principles

- Dark coloured shopfronts will often help to highlight the display area especially if well lit. Dark shades of green, grey, blue, red, browns, or black are traditional colours for historic shopfronts.
- Fluorescent colours will be out of place almost everywhere and will not be supported. Bright shades of yellow, orange and pink are generally inappropriate in sensitive historic areas.
- Minimalist and monochrome paint combinations combined with the use of a stylish script will result in a high quality scheme. Garish and clashing colour combinations should be avoided altogether.
- Varnish and wood stains, which will allow the timber grain and character to show as part of the finish, have essentially none or a low amount of pigment and as such they are susceptible to discolouring from water and sun. Therefore, the suppliers' specifications should be carefully checked for these effects.



Brick, ashlar stone, painted timber



Painted brick and timber stallriser



Painted timber mullion

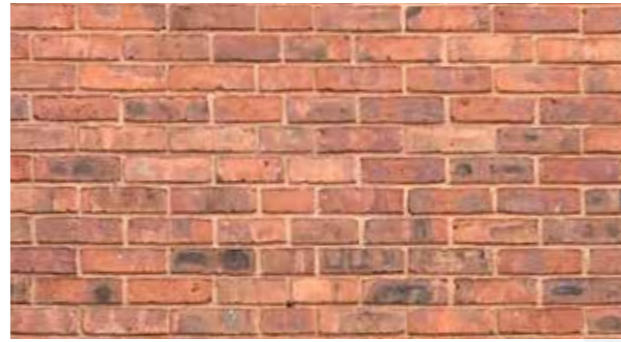

Red Brick

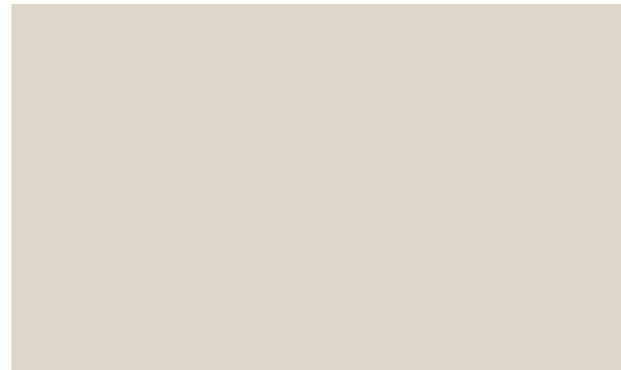

Aluminium



Ashlar Stone

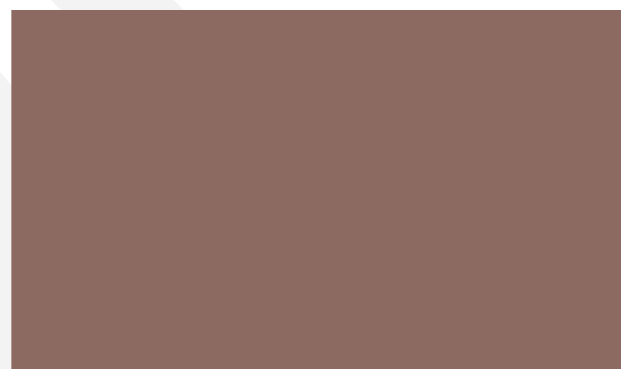
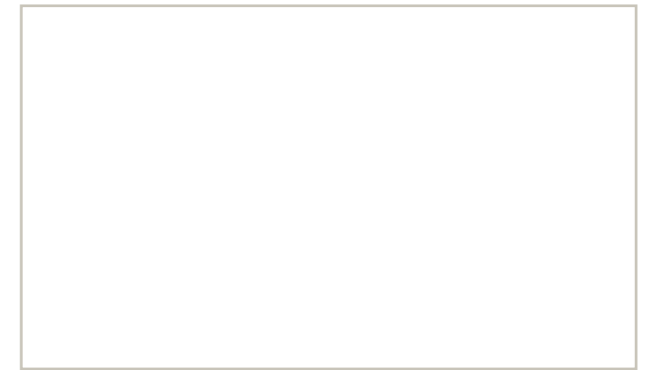

Ashlar stone, painted timber

Above: Colour swatches sympathetic to the local character of Yeovil

2.4 – Accessibility

In line with current regulations, new shopfronts should accommodate the needs of all people, allowing safe, easy and convenient access for all users of the building, including those with impaired abilities, elderly people and those with prams.

Good design principles

- Level access: where possible steps should be avoided and the shopfront entrance should be level and wide enough to allow entry for all users;
- Where a change of level is unavoidable, steps and ramps should be designed in line with Approved Document M of the Building regulations. Small changes in level may be able to be accommodated within the footway outside the shop; the Highway Authority for the area should be consulted in the first instance.
- Doors should be able to be operated easily by wheelchair users and those with limited strength;
- The needs of the partially sighted should be considered when designing a shopfront; distinguishing glass doors within large areas of glazing is difficult for the visually impaired. Incorporating stallrisers, glazing bars and suitable manifestation on the shopfront will assist in making the facade more legible.
- Forecourt displays and seating can enliven streets and will generally be permitted where it does not cause an obstruction to pedestrians or nuisance to any neighbouring residential occupiers. To prevent conflict, forecourts should be clearly delineated from the main pavement, allowing sufficient space for the free flow of pedestrians. Broadly speaking the required clearances are:
 - 3m for primary pedestrian routes, where there is heavy footfall (town centres, busy shopping areas and public transport nodes), and
 - 2m for all other pedestrian routes, where there is less footfall.
- These clearances should be kept free of any obstructions, including lamp posts and street furniture. As mentioned earlier in the document, the use of A-boards and similar type of on-street advertising should be avoided so as not to obstruct movement.
- The interior design and the shop service should also be considered, ensuring the layout is easy to navigate and providing assistance for people with hearing, visual, physical or mental impairments.

3. Repairs & Maintenance of Existing/Traditional Shopfronts

Where a traditional or historic shopfront exists, shop owners will be encouraged to retain and repair as necessary. Traditionally designed shopfronts are made of timber and sit within a traditional architectural framework around the opening. Across the country there are examples of historic timber shopfronts having survived for over two hundred years. This demonstrates that utilising good quality timber, detailed well and maintained adequately is a worthwhile investment. It is easily repairable without replacing the entire shopfront.

For repairs and maintenance, it is recommended to use good quality softwood suitable for external use, as such as Douglas Fir or British Columbian Pine, and hardwood for the cill.

The following principles should be followed for selecting timber:

- It should be suitable for outside use;
- It should be workable, i.e. it can be worked to the fine detailing;
- Its moisture content should be verified and the likelihood of movement;
- It should be that it is able to take a finish that will look good and be durable;
- It should be able to take a painted finish where varnish is not acceptable;
- It should be supplied from environmentally sustainable sources.

The life-span of the joinery will be extended if all the joint faces (especially the end grain) are primed before construction. Utilising suitable modern, microporous paint will assist timber that gets damp to dry out, however more traditional, linseed oil paints tend to be more flexible and less likely to crack. A good paint system, using long life paints, will mean less repainting over time and that includes good quality primers.

New shopfronts should incorporate trickle vents or opening lights to maintain adequate ventilation, which will prolong the life of the shopfront.

Annual checks and paint touch ups particularly around the cill and the joints in the framing will ensure a timber shopfront is maintained to a good standard. Where larger repairs are necessary, timber can be scarfed-in around the joints, whereas minor repairs can be undertaken using resins.

Rendered and timber-panelled stallrisers can be subjected to a fair amount of damage, particularly if they are carried down to the ground without any gap or damp proof course. Splash-back from the road and pavement surfaces will constantly leave them dirty and stained, causing long term damage if they are not regularly cleaned and maintained.

Overall building maintenance, ensuring that gutters and downpipes are clear will also protect the facade and shopfront below from rainwater overflow damage. Similarly, the flashing over the cornice should be regularly checked to ensure it is not cracked and properly tucked in to the wall above and not plant material is growing around it, causing damage to the building.



Figure 55. Resin repair to timber shopfront detail



Figure 56. Timber stallriser repair



Figure 57. A well maintained timber shopfront

4. Contemporary Shopfronts

As mentioned in earlier sections of this document shop owners are encouraged to repair original shopfronts, and/or to repair and re-establish the traditional architectural frame of the shopfront. However, there may be instances where it is necessary and/ or appropriate to propose a carefully proportioned, well resolved, high quality, modern design either within the traditional surround or within a carefully articulated new shop frame that reinterprets the proportions and form of the adjacent shopfronts in a contemporary manner. The design of modern replacement shopfronts should be of a high standard design in order to bring diversity and vitality to the street.

In new and contemporary buildings there can be more flexibility in the design of shopfronts which can enhance and enliven the local shopping environment. Nevertheless, these generally work better where a high degree of architectural or graphic design is input into the scheme. Innovative design solutions can be incorporated more easily in such instances, however the basic principles of traditional shopfront design which have stood the test of time should still be reflected, particularly in a street setting incorporating other more traditional shopfronts.



Above: Contemporary shopfront examples

5. Consents

Most alterations to a shopfront will require planning permission however, routine maintenance works generally will not. In the case of listed buildings and buildings within conservation areas there are further restrictions. This is to ensure that alterations and additions do not harm the appearance of the area and are sympathetic to the integrity of the original building. In addition, Advertisement Consent may also be required to display a shop sign. It is advisable to contact the Local Planning Authority team before carrying out any alterations or displaying advertising. The Council's Planning Enforcement Team holds powers of enforcement to ensure compliance with legislation, policies and guidance.

Every application will require an application form and it can be submitted electronically via the Planning Portal. The Planning Portal was established by UK government in 2002 to allow planning applications in England and Wales to be processed electronically. It is not administered by the Local Planning Authority. Please visit www.planningportal.co.uk/applications for more information on applications. Assistance in calculating fees for planning applications can also be found on the Planning Portal website.

5.1 – Planning Consent

The Local Planning Authority has a Validation Guide detailing the documents required for any Planning Application submitted to be validated. For further information and advice please contact the Local Planning Authority team.

In addition to the documents listed in therein, planning applications for new shopfronts should include:

- Fully detailed plans and full elevation drawings of the whole building frontage, showing the new shopfront to a scale of no smaller than 1:50;
- Full details of all materials proposed.

5.2 – Conservation: Listed Building Consent

Listed building consent will be required for any changes which will 'affect its character as a building of special architectural or historic interest'. An application for listed building consent must be submitted to the local planning authority prior to works being carried out. It should be noted that it is a criminal offence to carry out work which requires listed building consent without obtaining that consent.

In conservation areas or when the building is listed, the submitted information should be supplemented by:

- Elevation drawings showing the complete neighbouring buildings in relation to the proposal no smaller than 1:50 ;
- A detailed elevation of the proposed shopfront to a scale of no smaller than 1:25;
- Full coverage of details including sections through cornices, fascia, blind boxes, window frames and glazing bars, stall riser, doors and pistons and security grill enclosures at a scale of 1:5 or 1:10;
- Full details of all materials and colours proposed.

5.3 – Advertisement Consent

The Advertisement control system rules are set out in the Town and Country Planning (Control of Advertisements)(England) Regulations 2007. It is the responsibility of the Local Planning Authority to decide whether a particular advertisement should be permitted or not under these rules.

Applications for fascia advertisements on poorly proportioned shopfronts will raise concerns and must be carefully thought through. An existing poorly proportioned fascia space will not be considered sufficient reason to permit an advertisement which will be detrimental to the visual amenity of the area. The applicant will be encouraged to redesign the shopfront or design the signage such as to compensate for the fascia's poor proportions. Guidance of fascia design and signage is set out earlier in this document and should be followed.

As with full Planning Applications, there is a validation checklist for applications for Advertisement Consent. In addition to the normal drawings required to be submitted with a Planning Application, Advertisement drawing(s) (e.g. at a scale of 1:50 or 1:100) (showing advertisement size, siting, materials and colours to be used, height above ground, extent of projection and details of the method and colour(s) of illumination [if applicable]) are required to be submitted. For more detailed information on the above requirements please see the National/Local Validation Checklist on South Somerset District Council's Website: www.southsomerset.gov.uk and/or contact the Local Planning Authority team for further advice.

The Planning Department
South Somerset District Council
Brympton Way
Yeovil
Somerset
BA20 2HT

Tel: 01935 462462

Fax: 01935 462299

Email: planning@southsomerset.gov.uk

Website: www.southsomerset.gov.uk

5.4 – Building Regulations Consent

Depending on the extent of the works to be done to a shopfront, there may be the need to seek Building Regulations Approval. Building Regulations are concerned with the technical requirements associated with the construction process, including:

- The way in which the building is constructed;
- Structural stability;
- Means of escape;
- Fire precautions;
- Weather resistance;
- Energy conservation;
- Sound insulation;
- Access and facilities for all users.

As discussed above, many types of building work will require both planning and building regulations approval, applications for which are done separately.

6. Checklist

The following checklist should be used to ensure good design principles have been followed.

Shopfront relationship with building and wider street

- The shopfront should reflect and relate in scale, proportion and architectural style to the building in which it is set and to the wider parade of shops;
- The fascia proportions should respect the rest of the shopfront and the building in which it is set. It should not be too deep, wide or project forward from the face of the building. It should be positioned consistently with adjoining buildings;

Positive shopfront character

- Where an existing shopfront is to be retained and restored or an original shopfront to be reinstated, surviving historic features should be preserved and restored in a sensitive manner;
- Where a new shopfront is installed, it should draw particular attention to the component parts of good traditional shopfronts;
- Pilasters and consoles, decorated if appropriate, should be used to support the fascia as they form an important part of the overall shopfront design;
- Stallrisers provide a strong visual base to the shop window and add to security and protection of the window display;
- Entrance doors should be recessed and have a solid lower panel to match stallriser height.

Attractive display windows

- The shopfront window display should be subdivided by vertical and horizontal elements to avoid a large expansions of glass and a well-proportioned frontage. Glazing bars assist in to creating visual relief, rhythm and an attractive design;
- Obscured panels filled with advertising should be avoided.

Uncluttered shop signage and advertisements

- Generally signage should be kept to a minimum, avoiding visual cluttered, and integrated into the shopfront. It should serve to advertise the goods and services offered whilst respecting the character of the building and street scene;
- Projecting signage should be small, positioned at fascia level and not obscuring details of the shopfront or other parts of the building.

Preventing light pollution

- External illumination where necessary should be low key and discreetly positioned. It should be designed and sited so as not to cause disturbance to others, including residents and passing traffic;
- Internally illuminated fascia signs should be avoided altogether;
- Proposed lighting levels should be in keeping with the character of the area.

Fixtures, services and entrances integration

- Any canopies installed should be integrated into the shopfront, be retractable and allow sufficient clearance below for pedestrian movement;
- Suitable security measures, such as toughened glass, better internal lighting, internal video cameras and alarm systems are preferable to shutters and grilles;
- Where security shutters are necessary, they should be internally fitted, dark coloured and be of an open design. Guide rails and shutter boxes should be concealed and sensitively integrated into the shopfront design;
- Other fixtures, security features, services and secondary entrances should be integrate with and complement the building and shopfront;
- Services should generally be located to the rear of a building to remain out of view from the main street or screened from view as appropriate.

Materiality

- High quality and robust materials should be used in shopfront construction. They should be in keeping with the character and appearance of the building;
- Where traditional shopfronts are restored, original materials could be replicated.

Equality Act: access for all

- The shopfront must allow equal access to all, regardless of abilities;
- Forecourts should be clearly delineated from the main pedestrian routes, allowing sufficient clear space for pedestrian movement.
- Historic shopfront alterations should balance the requirement to preserve historic character with the needs of adequate access.

Other considerations

- Material considerations such as conservation design guides should be considered as and where appropriate;
- The repair of traditional shopfronts should be considered as a first option, as opposed to replacement;
- The design of shopfronts in modern buildings can allow for innovation and more flexibility in the design. Nevertheless incorporating basic principles of traditional shopfront design should produce successful results that can be an effective advertisement for the quality of the establishment.

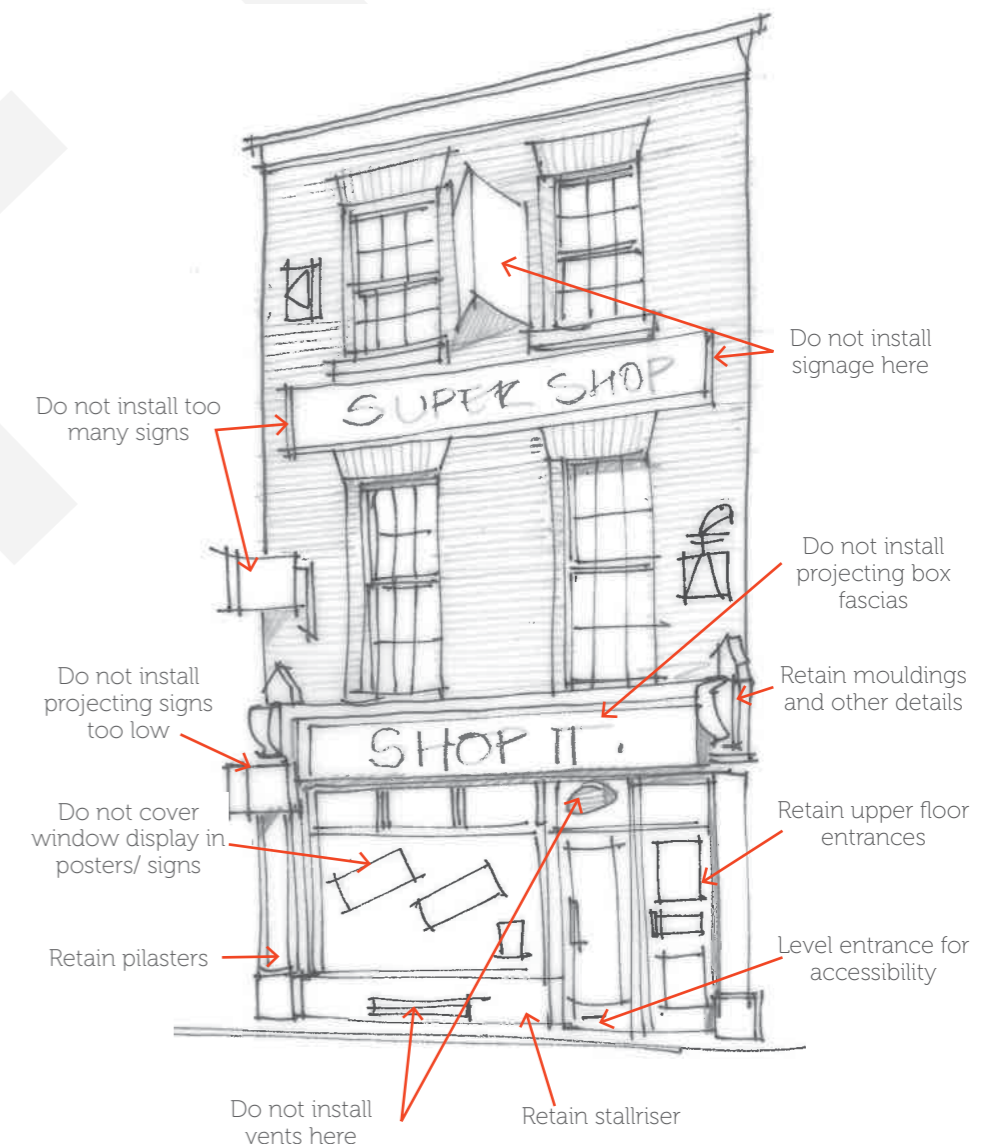

7. References and Further Advice

1. SSDC: South Somerset Local Plan (2006 – 2028) (Adopted March 2015)
2. English Historic Towns Forum: Book of Details & Good Practice in Shopfront Design
3. <https://www.southsomerset.gov.uk/services/planning/>
4. <https://www.planningportal.co.uk/info/200127/planning>
5. <https://legacy.southsomerset.gov.uk/your-area.aspx?addressid=001P5900LI000>
6. Department for Communities and Local Government: Outdoor advertisements and signs: a guide for advertisers, June 2007
7. Historic England: Making Changes to Heritage Assets, Advice Note 2
8. SSDC: Your Listed Building A Guide For Owners And Occupiers
9. SSDC: Validation Guide – What do I need?
10. SSDC: The design of Shopfronts, Signs and Security Measures
11. SSDC: South Western Terrace SPG
12. Secured by Design: Commercial Developments 2015
13. Technical advice on security can be sought from the local Architectural Liaison Officer and Crime Prevention Design Advisors through <https://www.securedbydesign.com/contact-us/national-network-of-designing-out-crime-officers?view=article&id=308#avon-somerset-constabulary>

